

Lathe Coordinate System

MORI SEIKI
THE MACHINE TOOL COMPANY

COORDINATES

2. X-Axis and Z-Axis

Basic model of NC lathe has two numerically controlled axes, called X-axis and Z-axis.

X-axis The axis along which the cross slide moves.

Z-axis The axis along which the carriage moves.

The direction of an axis is determined by the positive (plus) and negative (minus) signs.

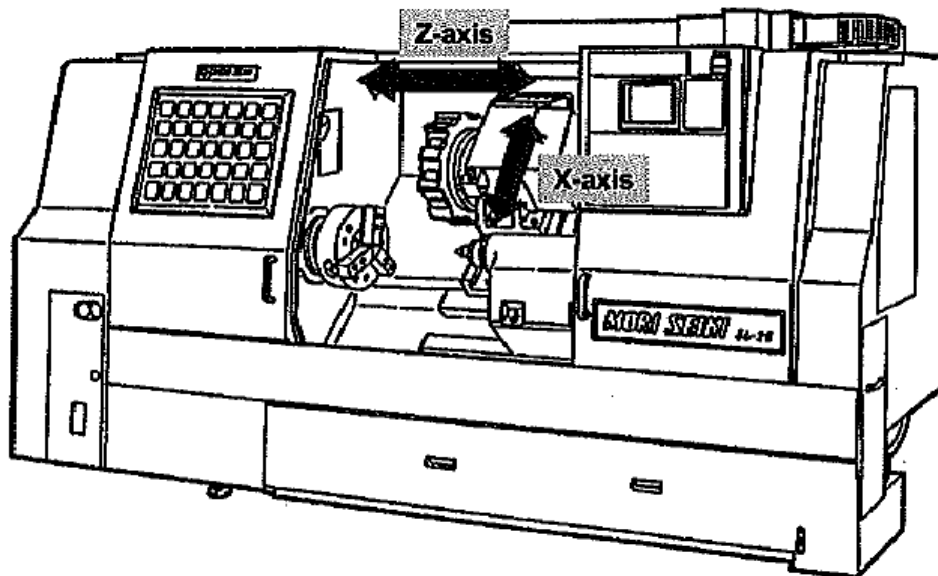

Workpiece Zero Point

- Coordinate system zero point is
 - centerline of spindle (X zero)
 - with normal spindle rotation, machining is in +X
 - back face of part (Z zero)
 - +Z is machining part
- X dimensions are *diameter*, not radius

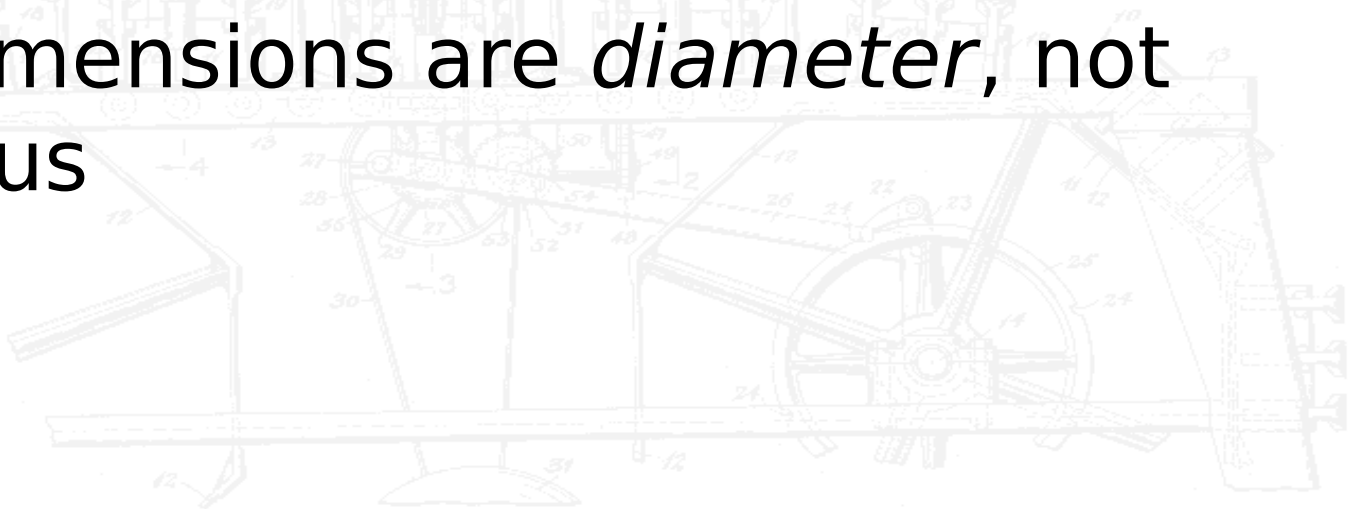

Workpiece Zero Point

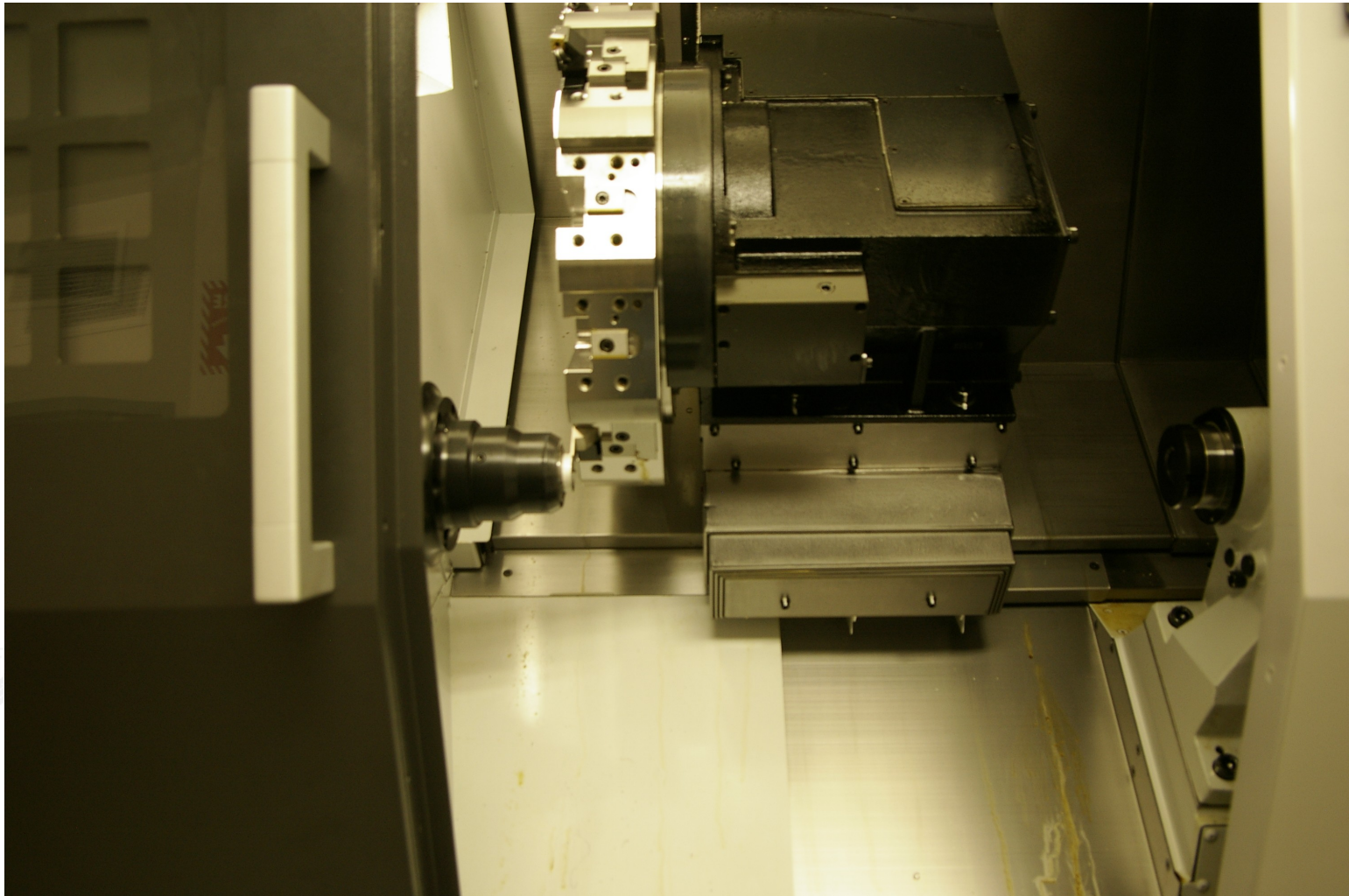

Workpiece Zero Point

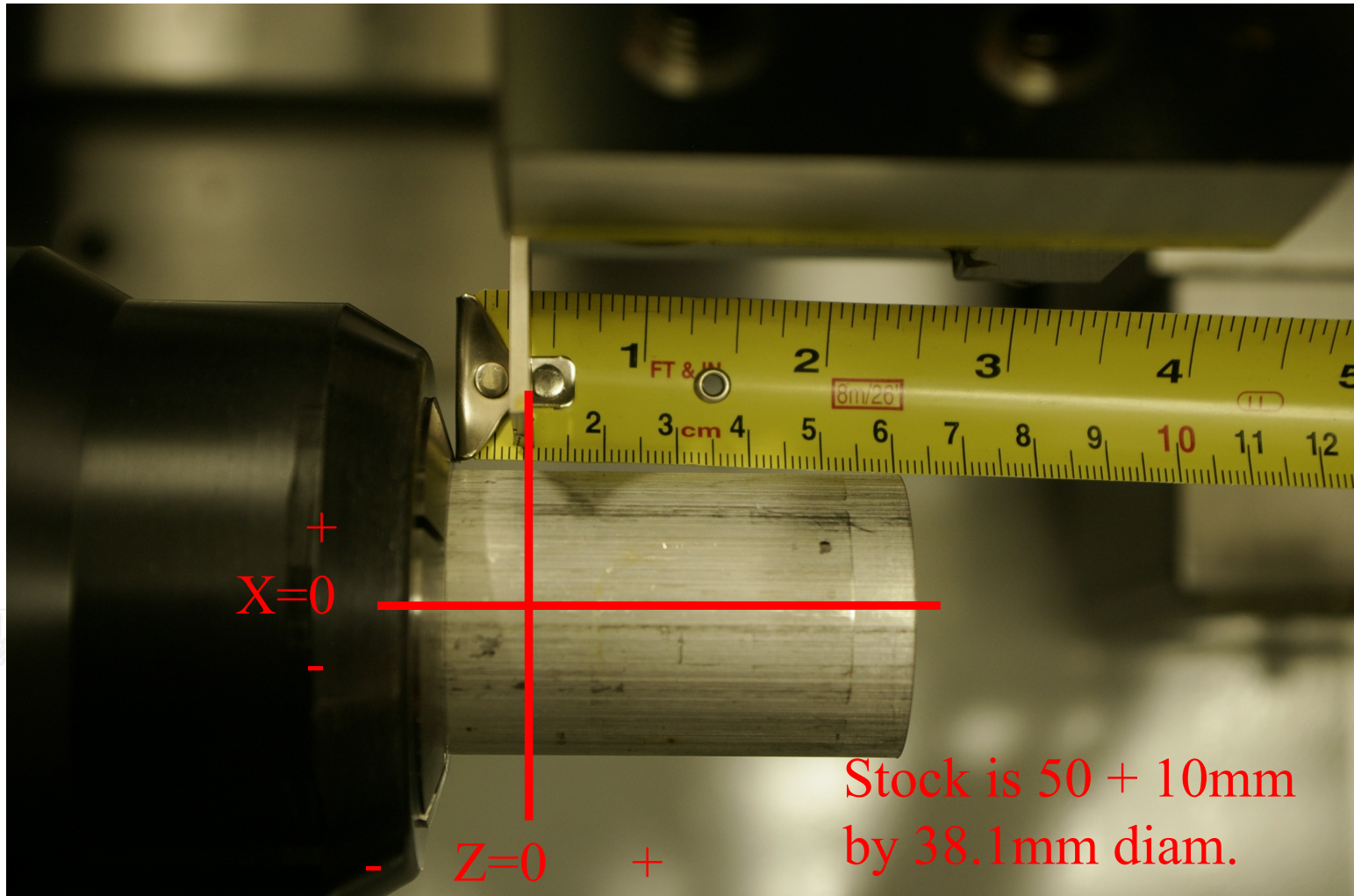

4. Tool Command Point

a) O.D./Face Turning

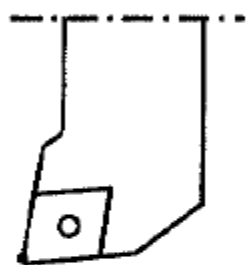

b) O.D. Grooving

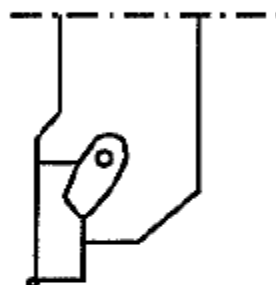

c) O.D. Threading

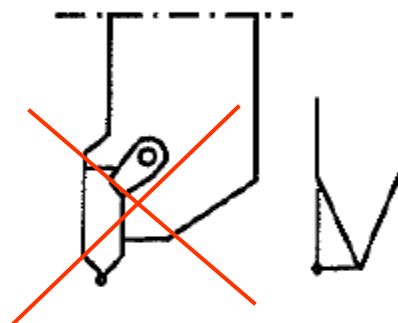

d) I.D. Turning



e) I.D. Grooving

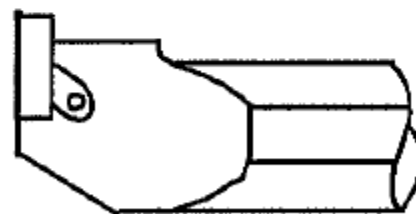

Example

Let's find out the dimensional data (actually, coordinate values) of five points (① to ⑤) in the drawing below.

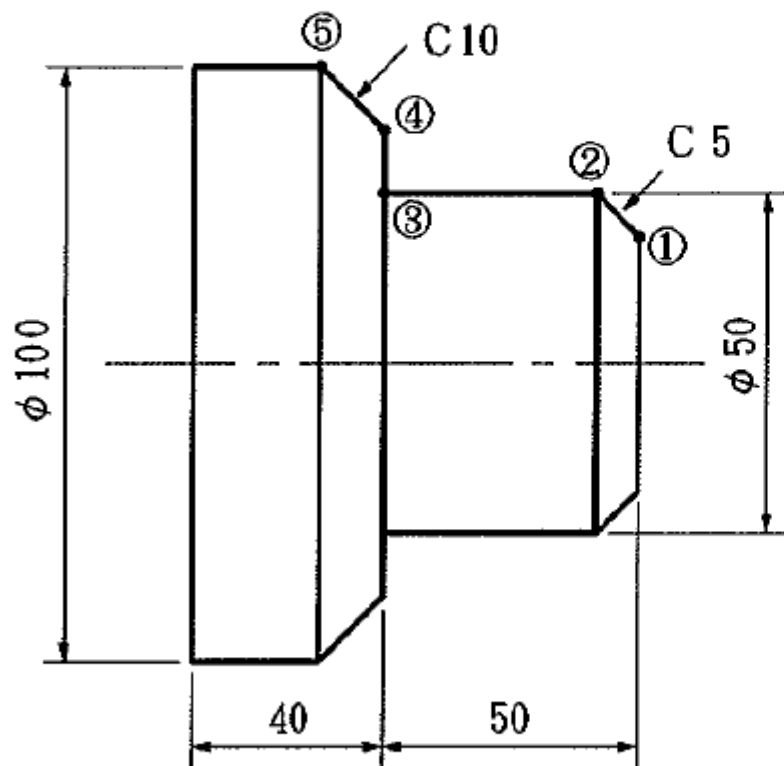

Z=0

(Fig. 1-6)

- 0 _____
- ① X_____ Z_____
- ② X_____ Z_____
- ③ X_____ Z_____
- ④ X_____ Z_____
- ⑤ X_____ Z_____

M30

Absolute Programming

- Point 1 : X40.0 Z90.0
- Point 2: X50.0 Z85.0
- Point 3: X50.0 Z40.0
- Point 4: X80.0 Z40.0
- Point 5: X100.0 Z30.0

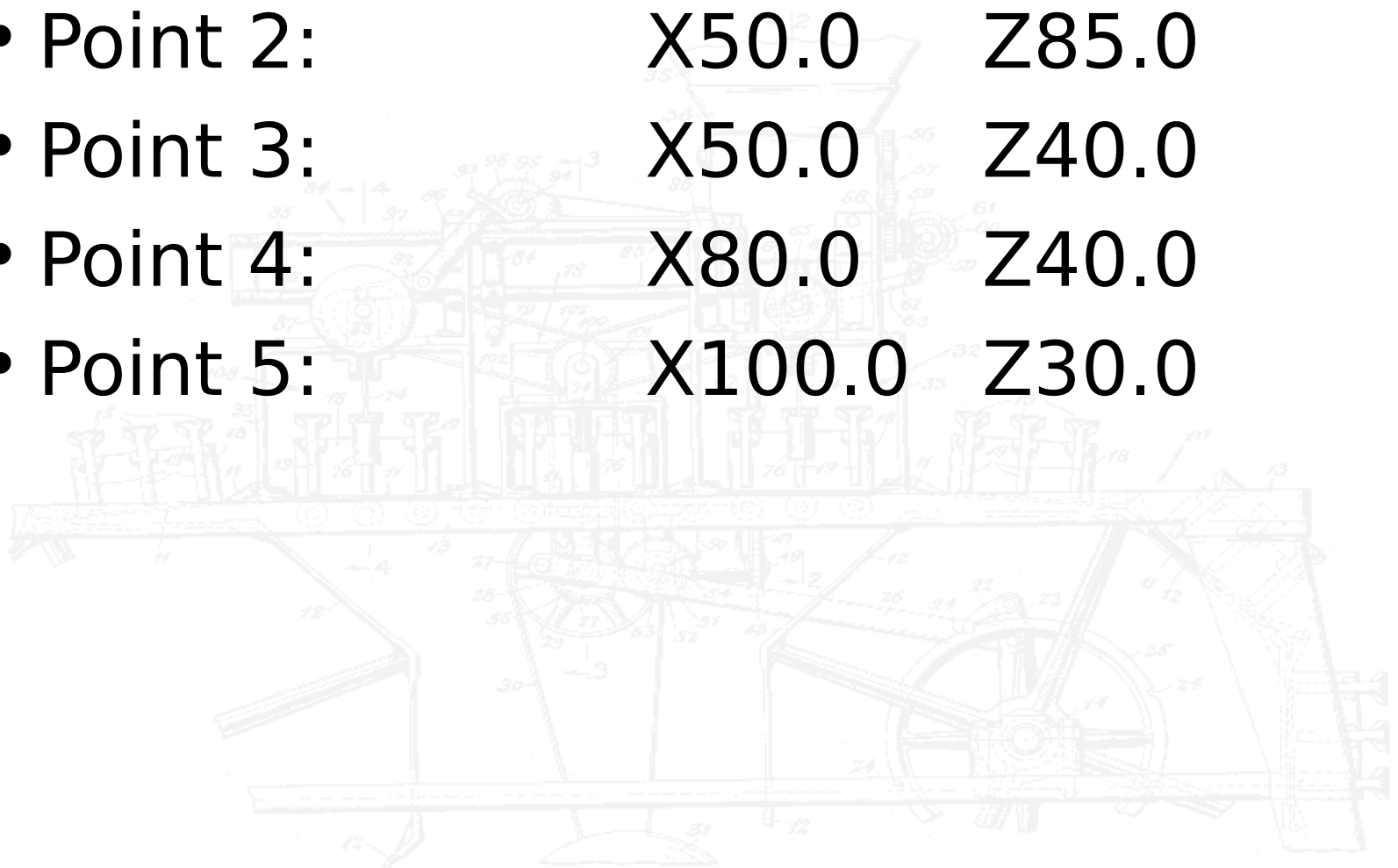

Incremental Programming

- In incremental programming, only the change in X and Z are given. Change in X is U, change in Z is W.
- ONLY USE FOR MOVING AWAY FROM PART, NOT CUTTING!
- Point 1: X40.0 Z90.0
- Point 2: U10.0 W-5.0
- Point 3: W-45.0
- Point 4: U30.0
- Point 5: U20.0 W-10.0

7. Cutting Conditions

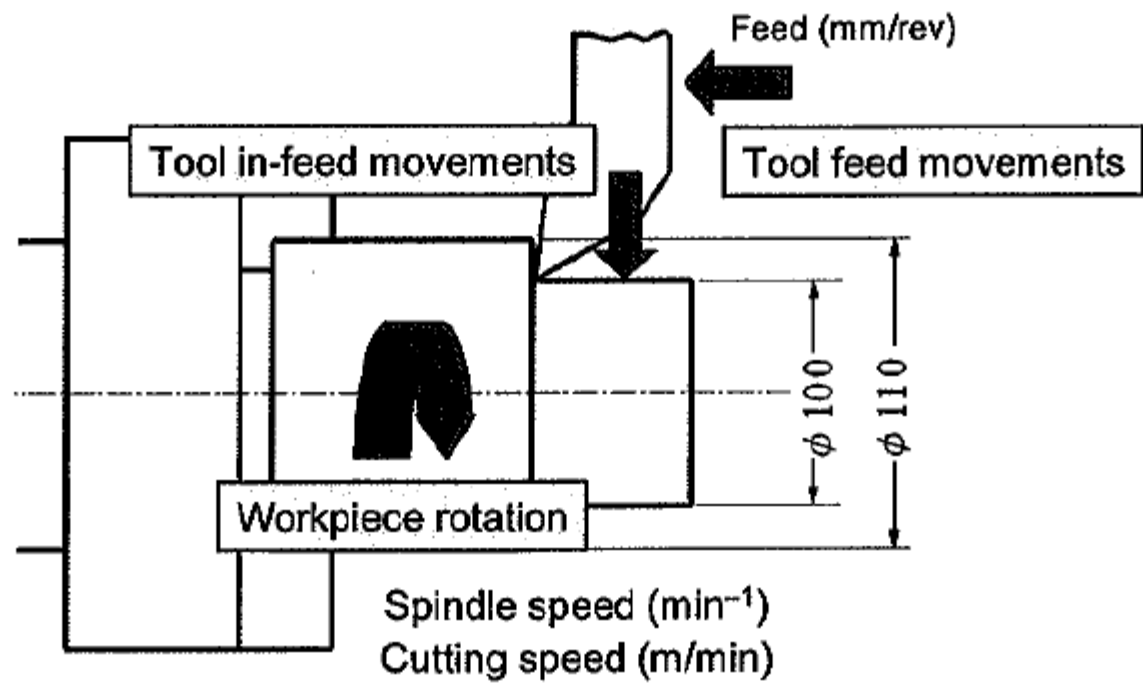

7.1 How to Determine Cutting Conditions

- (1) Cutting speed (spindle speed) : Material and shape of workpiece
Insert material (hardness in high temperature and wear resistivity)
- (2) Cutting feedrate : Rigidity of the machine and tools
Nose radius of insert ($F_{max.} \leq Nr/2$)
Chip breaker shape
Surface finish specified in the drawing → Nose radius
- (3) Depth of cut : Rigidity of the machine and tools
Main motor output
Insert thickness ($D_{max} \leq$ Insert thickness)
Cutting edge length of insert
Chip breaker shape
- (4) Workpiece holding conditions : Workpiece holding status and method
Workpiece shape
Size and balance of jaws
Chucking pressure
Tailstock spindle thrust force

Major Five Functions That Control NC Lathe

1. **G Function: Preparatory function**

Commands related to X-/Z-axis feed control/G00, G01, G02

2. **M Function: Miscellaneous function**

ON/OFF commands output from the CNC to the NC lathe/M00, M03, M08

3. **T Function: Tool selection function**

Calling the tool to be used/T0101 (4-digit T code)

4. **S Function: Spindle speed (min^{-1}) and cutting speed (m/min)**

Spindle speed command/S500 (= 500 min^{-1})

Cutting speed command/S200 (= 200 m/min)

5. **F Function: Feedrate command (mm/rev)**

Tool feedrate command/F0.3 (= 0.3 mm/rev)

CNC Lathe Programming

1 block

```
N 000000 G 00 X00.0 Z000.0 M 00 S 00 T 00 ;
```

Sequence number Preparatory function Dimension word Miscellaneous function Spindle function Tool function

End of block

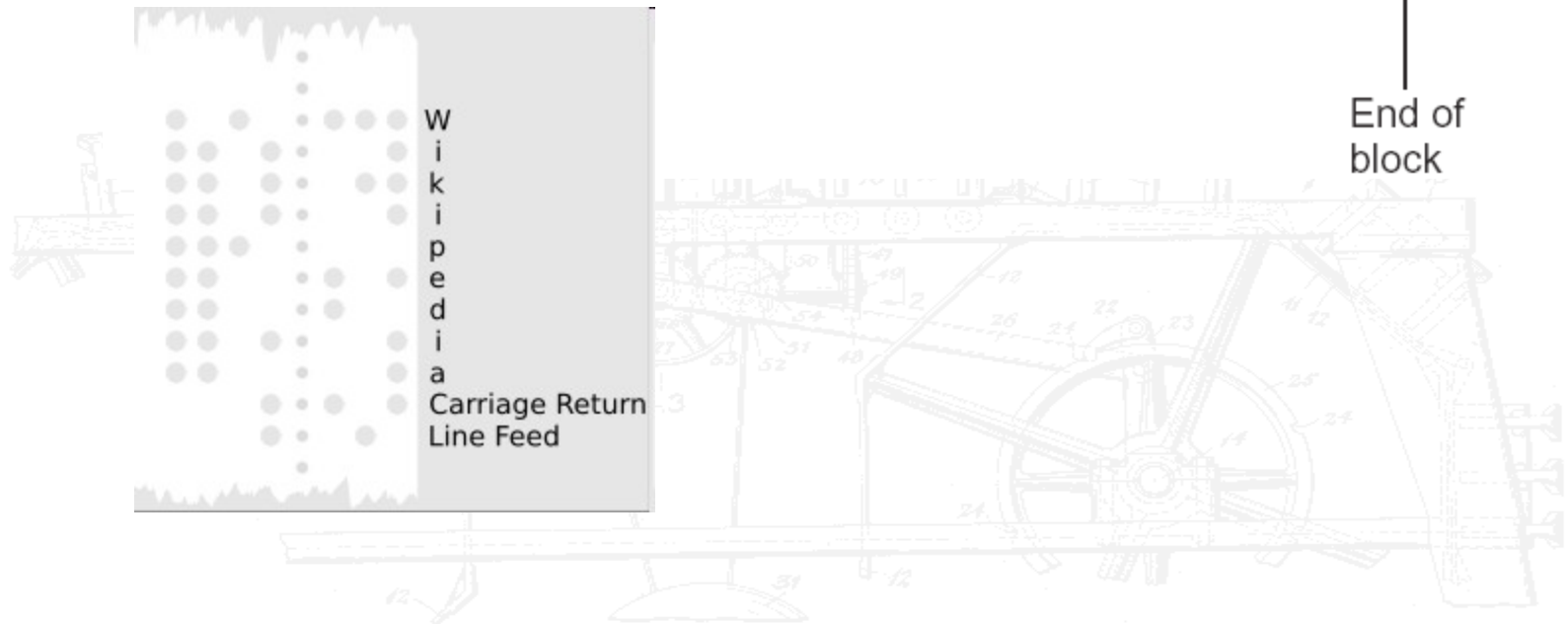

G-Codes for Turning

G0	Rapid positioning
G1	Linear interpolation (feeding)
G2	CW Circular interpolation
G3	CCW Circular interpolation
G4	Dwell
G20	Inch system
G21	Metric system
G28	Return to reference point
G50	Limit spindle speed

G-Codes for Turning

G54	Select work coord system #1
G70	Finishing cycle
G71	Roughing cycle
G72	Facing cycle
G76	Threading cycle
G96	Constant <i>surface</i> speed mode
G97	Constant <i>spindle</i> speed mode
G98	Feed per minute mode
G99	Feed per revolution mode

M-Codes for Turning

M0	Program Stop
M1	Optional Program Stop
M3	Start spindle (normal rotation)
M4	Start spindle (reverse rotation)
M5	Stop spindle
M8	Start coolant
M9	Stop coolant
M10	Close chuck
M11	Open chuck
M30	Program end

Variables and Math

- Variables:
 - #1-33 (local vars for macros)
 - #100-199 (zeroed on powercycle)
 - #500 to 999 (survive powercycle)
 - Don't change vars above #1000: these are system variables.
 - math:
 - [#500 + 1.0]
 - [#500 + #510]
 - [#500 + [#512/2.0]]

Example Program

```
%  
O1 (THAT'S AN OH NOT A ZERO)  
; (EXAMPLE PROG - TURN PLUG 20.0MM OD X 17MM LONG)  
; (STOCK: ALUM 1.5" X 17MM + 10MM)  
;  
; (T1- CNMG 55DEG DIAMOND)  
; (T2- VNMG 15DEG DIAMOND)  
; (T10- 3.175MM CUTOFF)  
;  
; (VARIABLES)  
#500=38.1 (STOCK DIAMETER)  
#501=17.0 (STOCK LENGTH)  
#502=150.0 (SURFACE M/MIN FOR CUTTING ALUM)  
#503=0.2 (ROUGHING FEED: MM/REV)  
;  
N1  
G54 (WORK OFFSET)  
G21 (METRIC)  
G28 U0 W0 (GO HOME)  
G50 S2000 (MAX SPINDLE SPEED)
```

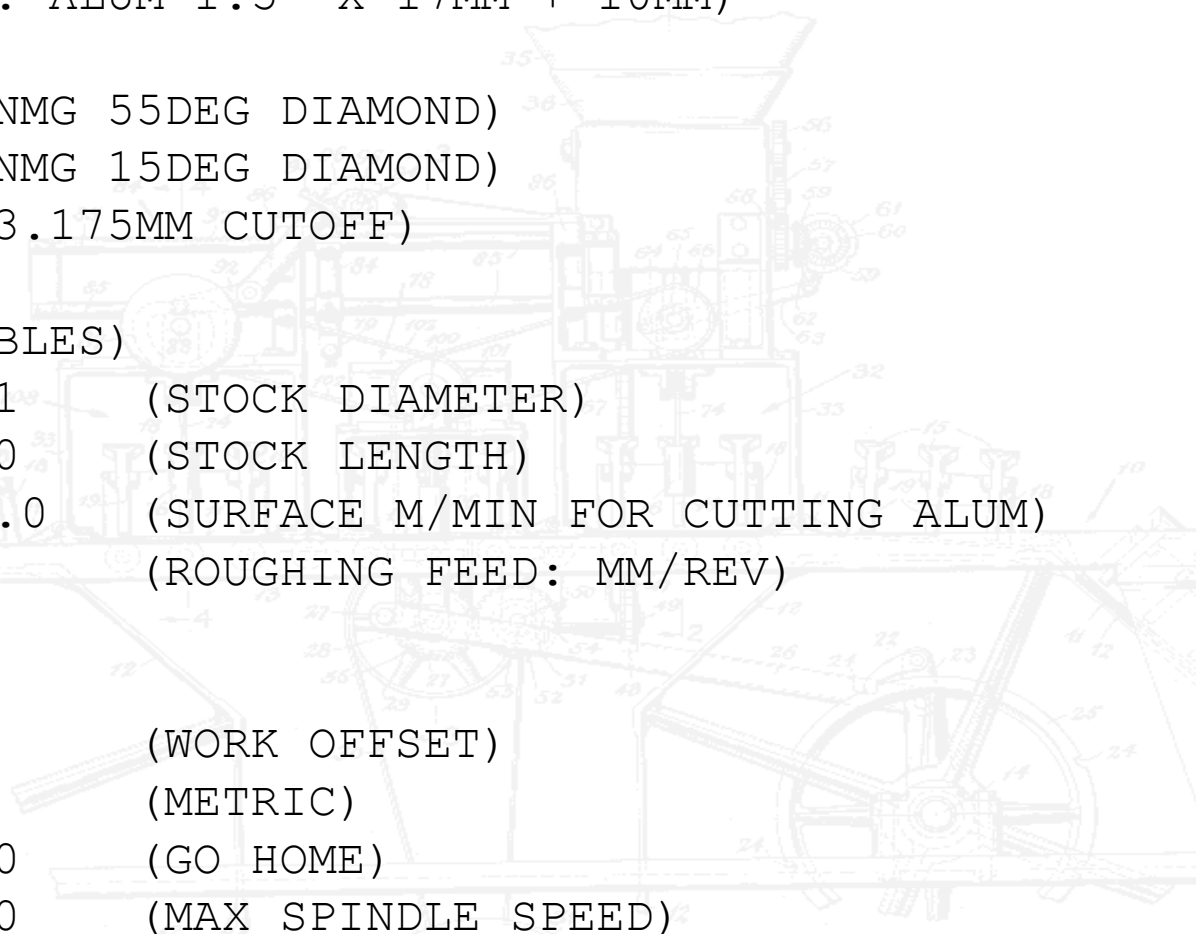

```
;
; (ROUGH OD 38.0 TO 20.5MM)
; (USE 2.0MM DEPTH OF CUT -> 8 PASSES)
;
N2
G00 T0101          (55DEG DIAMOND TOOL, TOOL 1)
G50 S2000          (CLAMP SPEED AT MAX 2000)
G96 S#502          (CONST SURF SPEED)
G99                (FEED PER REV)
G00 X[#500 + 0.5] Z#501  (INITIAL POINT FOR ROUGHING)
M03                (SPINDLE ON)
M08                (TURN ON COOLANT)
G00 X36.0 Z#501
G01 X36.0 Z5.5 F#503  (FIRST PASS)
G01 X[#500+0.5] F#503 (RETRACT X)
G00 Z#501           (RETRACT Z)
G00 X34.0
G01 X34.0 Z5.5 F#503 (SECOND PASS)
G01 X[#500+0.5] F#503
G00 Z#501
G00 X32.0
G01 X32.0 Z5.5 F#503 (THIRD PASS)
G01 X[#500+0.5] F#503
...
```

```
;
; (FINISH OD 20.0MM)
;
N3
G00 T0202 (VNMG 15DEG DIAMOND)
G00 X19.0 (POSITION FOR START OF CHAMFER)
G00 Z[#501+0.5]
G01 X20.0 Z[#501-0.5] F#504 (CHAMFER 0.5MM)
G01 Z0.0 F#504 (FINISH TURN)
G01 X[#500+0.5] F0.1 (BACK OFF)
M09
M05
G28 U0 W0 (GO HOME)
M01
```

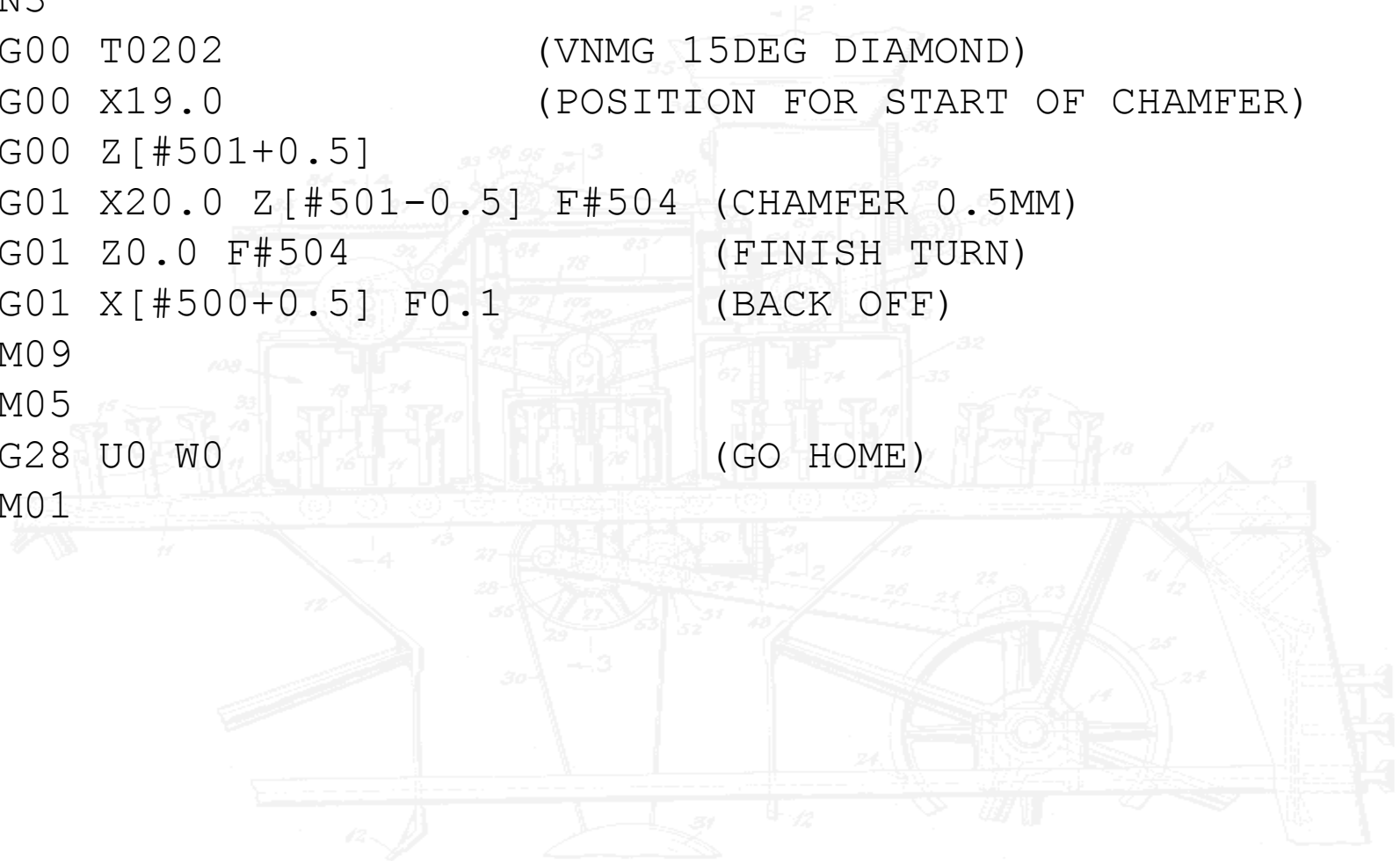

```
;
; (CUTOFF)
G00 T1010
G00 Z0.0 (CUTOFF BLADE IS 3.175MM WIDE)
G00 X[#500+2.0]
M03
M08
G50 S1000 (CLAMP SPEED AT MAX 1000RPM)
G96 S#502 (CSS)
G01 X-0.1 F0.05 (CUTOFF)
G01 X[#500+2.0] F4.0 (RETRACT)
M09
M05
G28 U0 W0
M30 (END PROGRAM)
%
```

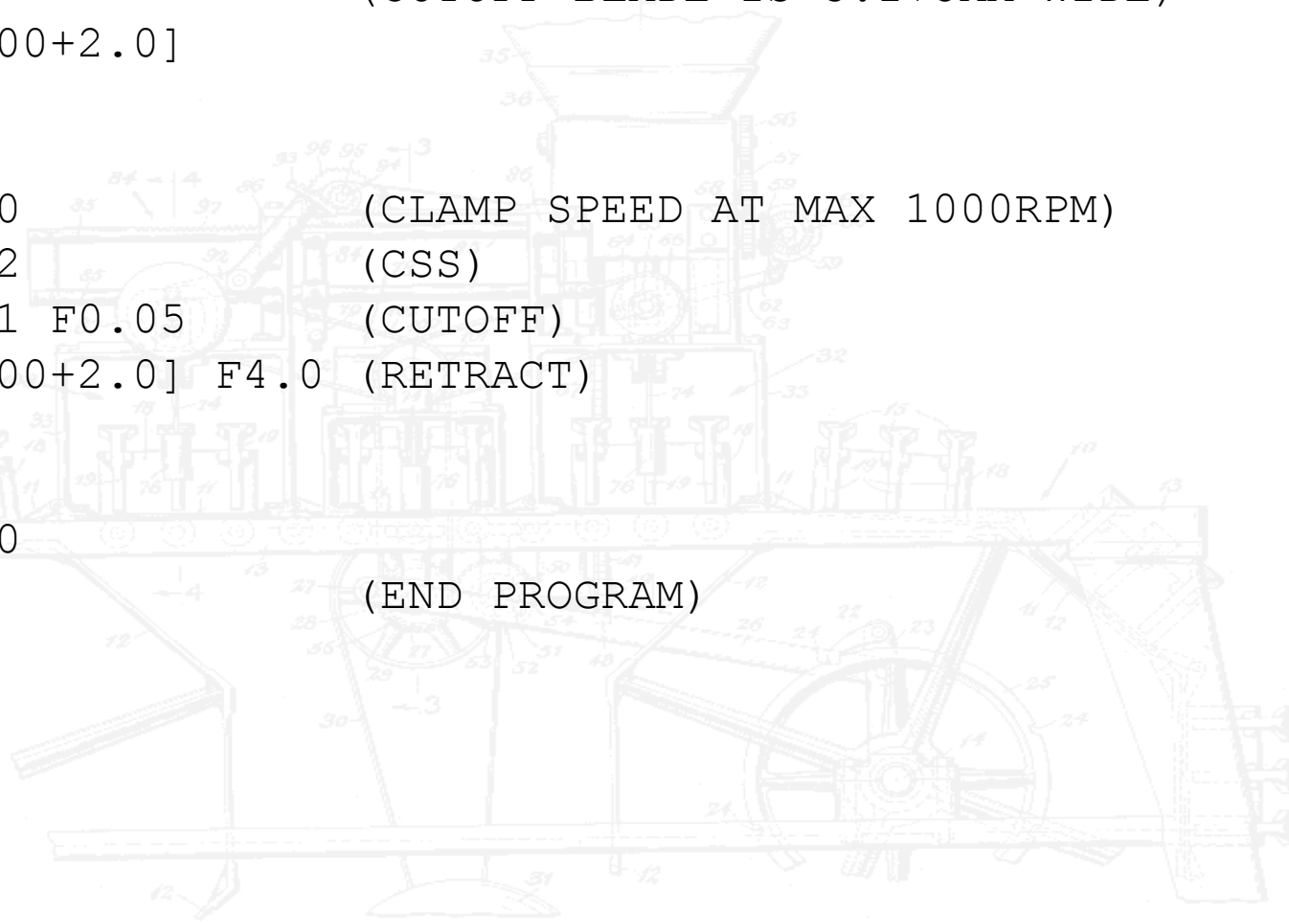

Assignment for Lab

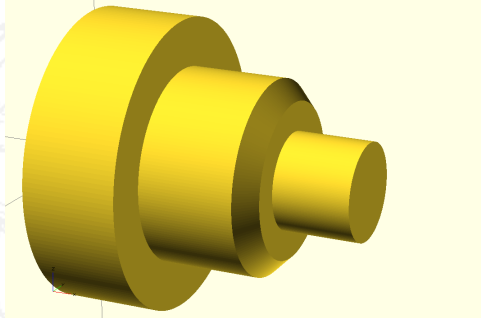
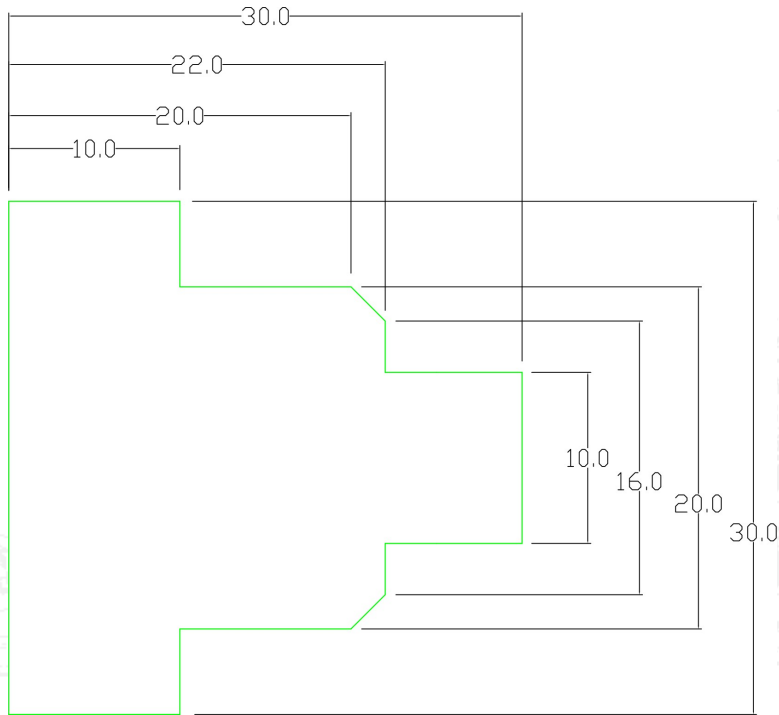

Special Tips

- NEVER DO A TOOL CHANGE AWAY FROM HOME! (G28 U0 W0)
- ALWAYS PUT A DECIMAL POINT AFTER DIMENSIONAL NUMBERS (no decimal --> microns)
- USE ALL CAPS IN YOUR PROGRAM (lowercase gets dropped)
- DON'T GET "OHS" AND "ZEROS" MIXED UP. PROGRAM NAME STARTS WITH "OH", NOT ZERO