

Contents	
1	Introduction
2	Pin Configuration
3	Power Supply
4	Software
5	I/O Headers and Power Supply

FREEDOM KL25Z

Revisions & Change Log			
Rev	Description	Date	Approved
X1	Initial Draft	04/10/12	M. NORMAN
A	Release to production	05/03/12	M. NORMAN
B	Prototype redefinition. KL25 XTAL capacitors C16 & C19 changed from 10pF DNP to 22pF populated. Defined A5 signal from K20 MCU	05/09/12	M. NORMAN
C	Prototype release. Fixed J10 orientation according to Arduino R3 specification	05/21/12	M. NORMAN
CX1	Prototype Re-spin. Changed two pin headers to DNP bottom-shorting headers. Added support to AT45DB161D-S or AT45DB161E-SSHD SPI Flash Memory. Added 2pin header (J11) for on-board MCU programming isolation. Redefined KL25 power netnames. Changed USB connectors part numbers J5 and J7 Changed KL25 XTAL 1M resistor (R25) to DNP. Changed X-FREEDOM-KL25Z board name to FRDM-KL25Z	06/29/12	M. NORMAN
D	Pilot release. Changed 2pin header (J11) location for on-board MCU SWD CLK isolation. Changed to DNP non-production BOM parts BT1, J1, J2, J3, J4, J6, J9, J10, TP6, U5, J8 Removed OpenSDA leverage hint voltage legend	07/10/12	M. NORMAN
DX1	Production Re-spin. Fixing V. drop in ADC by changing SH1 for R77 & R80, and 3.0V zener (D9) also changed BAT54C rectifiers (D1, D2, D5) for MBR120VLSFT1G diodes (D6, D7, D8, D10, D11, D12, D13 to enhance VF curve and current capability. Added J20 header to bypass D12 vdrop. Changed J4 and J3 to no bottom-shorting headers and added R73 & R74 0-ohm instead, along with R81 for current measuring Added USB host functionality without electrical protection by placing J21 and R82 options. Updated KL25 symbol TPM to FTM function misnaming	01/22/13	M. NORMAN
E	Production Re-spin release. Adding 5V buck-boost VR support by 1x3 pin header J22 and C26-29 10uF capacitors	01/30/13	M. NORMAN

		Automotive, Industrial & Multi-Market Solutions Group 6501 William Cannon Drive West Austin, TX 78735-6598	
ICAP Classification: FCP: FLUC: PUB: X			
Designer: RAFAEL DEL REY	Drawing Title: FRDM-KL25Z		
Drawn by: RAFAEL DEL REY	Page Title: TITLE PAGE		
Approved: MICHAEL NORMAN	Size C	Document Number SCH-27556 PDF: SPF-27556	Rev E
Date: Thursday, January 31, 2013 Sheet 1 of 5			

All polarized capacitors are aluminum electrolytic

2. Interrupted lines coded with the same letter or letter combinations are electrically connected.
3. Device type number is for reference only. The number varies with the manufacturer.
4. Special signal usage:
 _B Denotes - Active-Low Signal
 <> or [] Denotes - Vectored Signals
5. Interpret diagram in accordance with American National Standards Institute specifications, current revision, with the exception of logic block symbology.

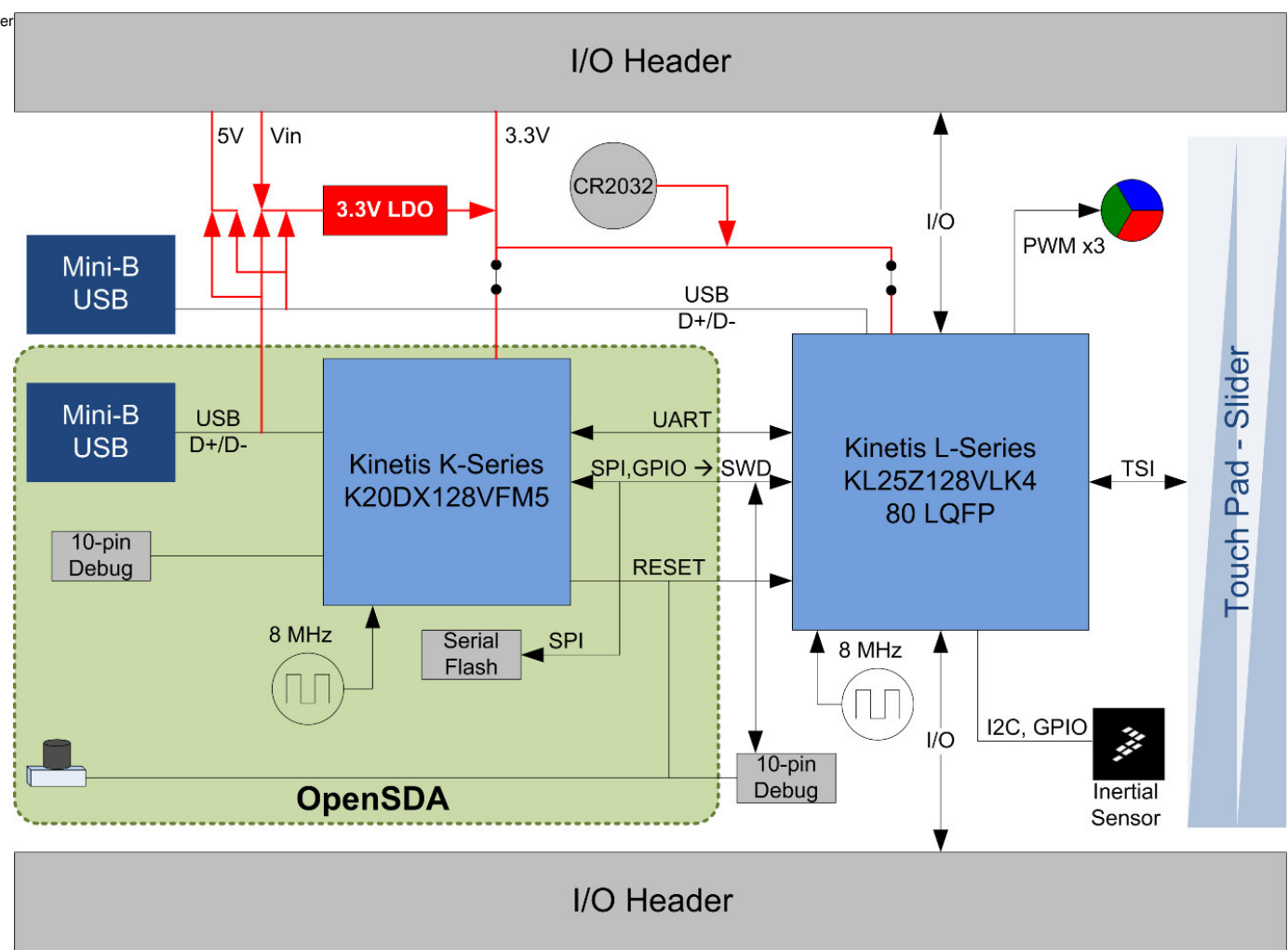

 — Indicates optional items that will **not** be populated by default

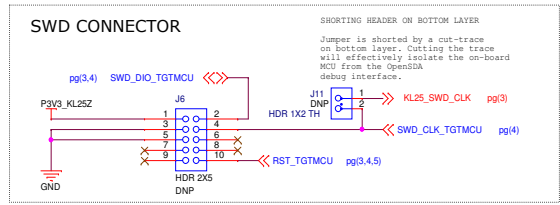
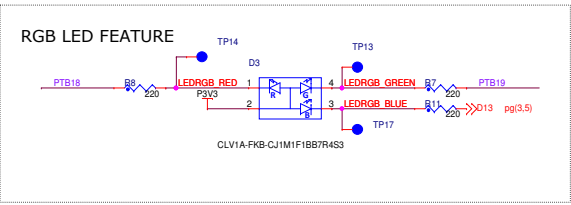
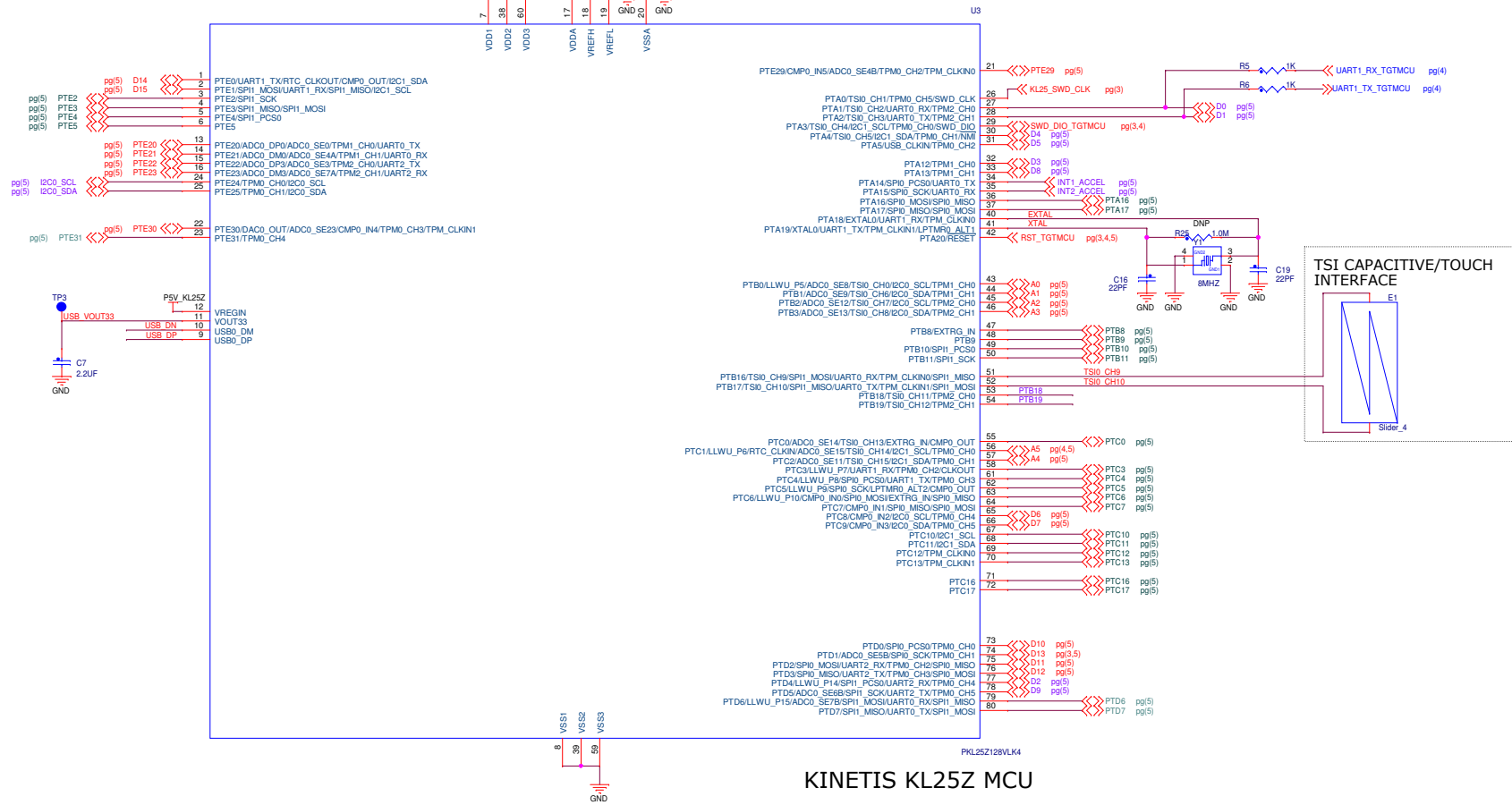
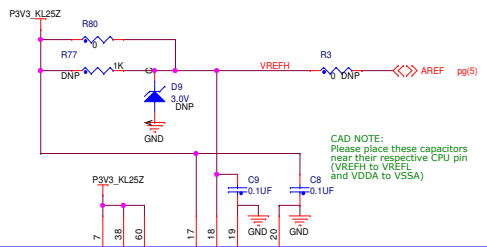
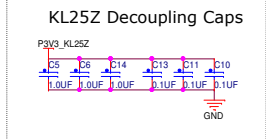
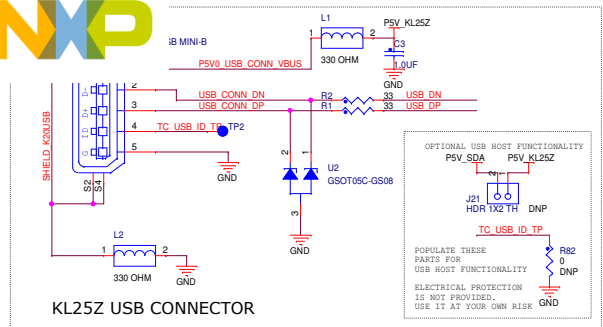

freescale

ICAP Classification: FCP: FIUC: PUB: X
Drawing Title: **FRDM-KL25Z**
Page Title: **KL25Z MCU**
Size C Document Number SCH-27556 | PDF: SPF-27556 Rev E
Date: Wednesday, January 30, 2013 Sheet 3 of 5

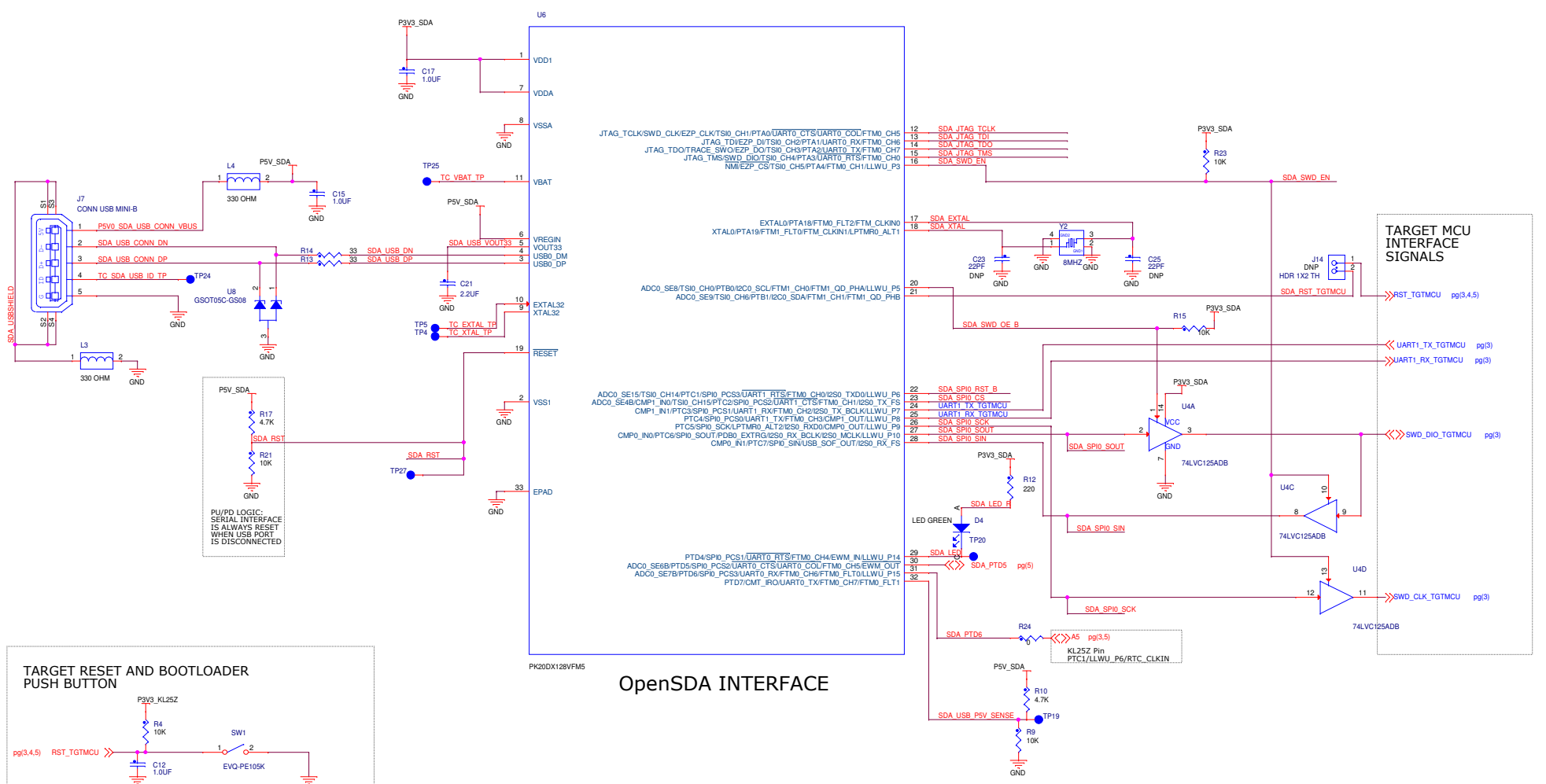

OpenSDA INTERFACE

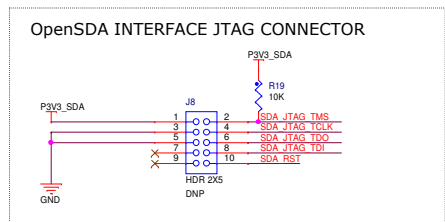
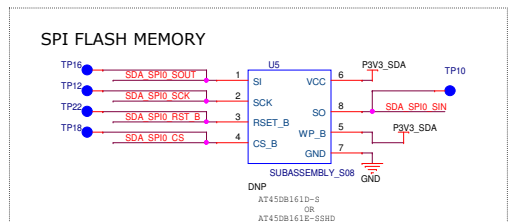
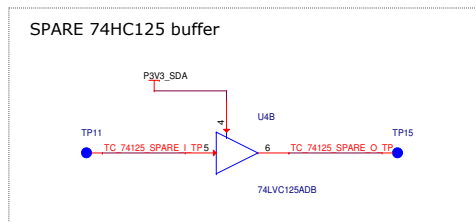
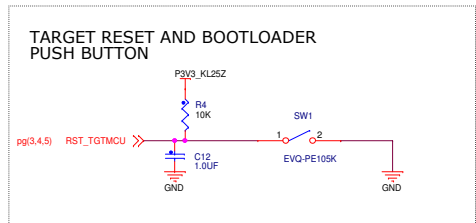

ICAP Classification: FCP:	FIUC: PUBI: X
FRDM-KL25Z	
OpenSDA interface	
Size C	Document Number SCH-27556 PDF: SPF-27556
Date: Thursday, January 31, 2013	Sheet 4 of 5

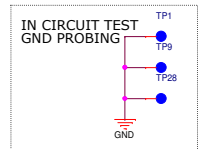
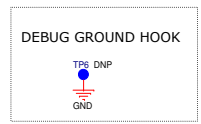
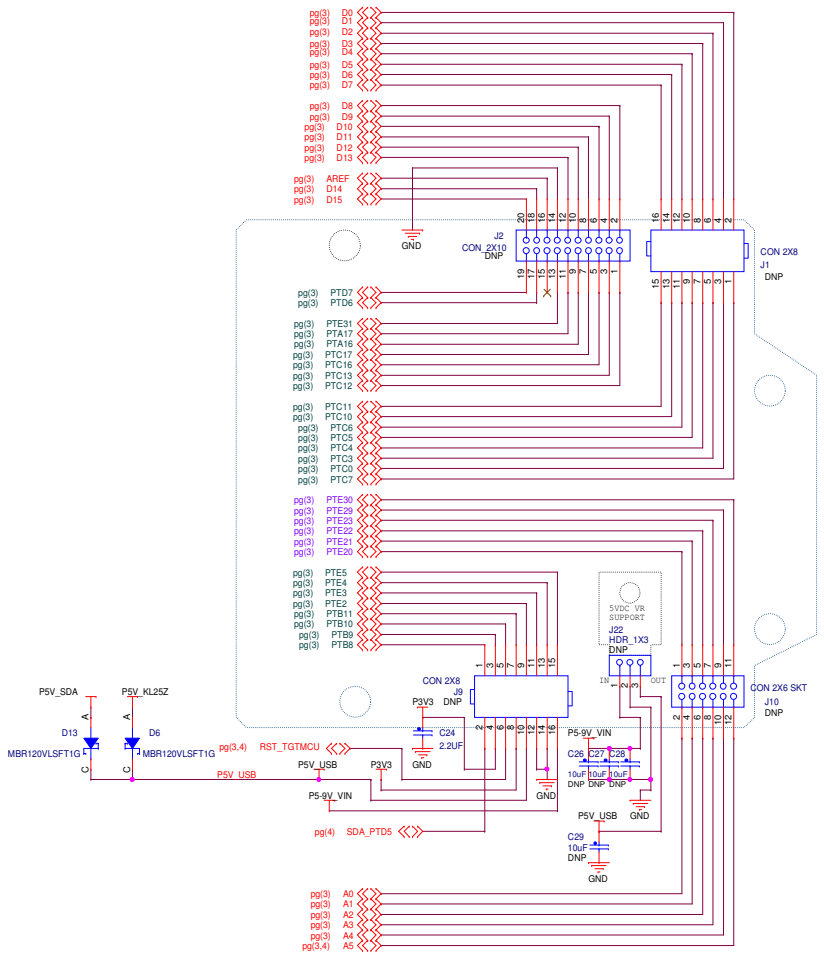
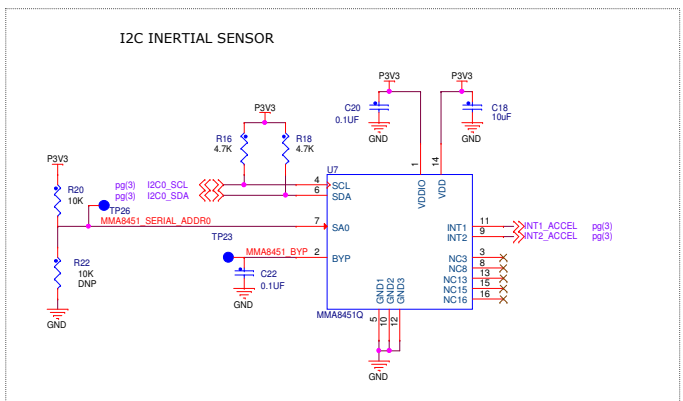
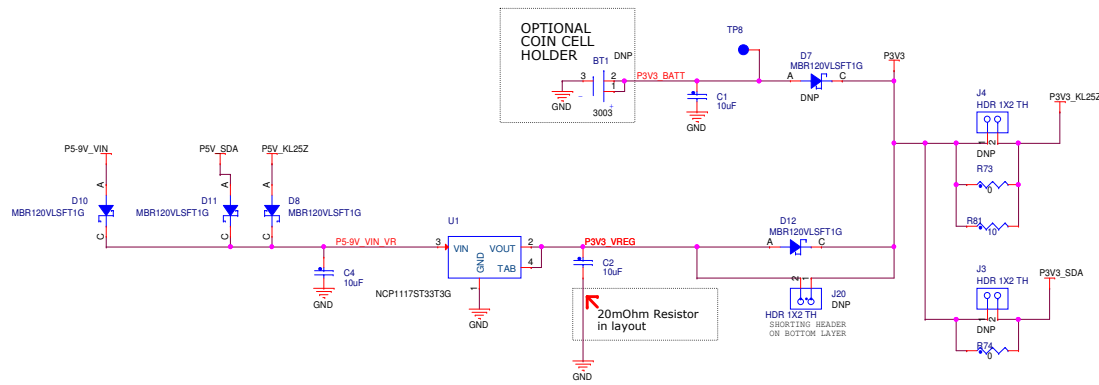

freescale

ICAP Classification: FCP: FIUC: PUBI: X
 Drawing Title: **FRDM-KL25Z**

Page Title: **ARDUINO SHIELDS & PWR SUPPLY**

Size C	Document Number SCH-27556 PDF: SPF-27556	Rev E
Date: Thursday, January 31, 2013	Sheet 5 of 5	