





SYMPOSIUM INTRODUCTION

Open Source Solutions in Experimental Design: An Introduction to the Symposium

Richelle L. Tanner ^{*} and Kirt L. Onthank [†]

^{*}Environmental Science & Policy Program, Chapman University, Orange, CA 92866, USA; [†]Department of Biological Sciences, Walla Walla University, College Place, WA 99324, USA

From the symposium “Open source solutions in experimental design” presented at the annual meeting of the Society for Integrative and Comparative Biology virtual annual meeting, January 3–February 28, 2022.

¹E-mail: richelle.tanner@richelletanner.com

Synopsis The Open Science movement has increased dramatically in popularity with deserved calls to action around transparency, access to resources, and inclusion in our field. However, its practical applications within experimental design have been slow to uptake, with researchers unsure where to even start with the dizzying array of open source hardware and software solutions available. The perceived time investment and unknown cost, especially in implementing open source hardware, has stagnated the implementation of inexpensive experimental solutions, but we sought to increase awareness to lower the barrier to participation in this space. While there are countless technical and financial advantages to integrating open source solutions into every biologist’s experimental design, we put an emphasis on the “people” part of the equation in our symposium. This symposium championed innovative experimental designs by early career Society for Integrative and Comparative Biology researchers across all fields of biology, from plants to animals, in the lab or in the field, or even virtually engaging with the public and students. The Open Science movement operates within community norms that champion transparency, continuous development, and collaboration. These values are congruent with the priorities of reducing barriers to participation in science, and we hope our symposium’s collection of open source solutions encourages readers to adopt these or other innovative designs into their own experimentation.

Introduction

The symposium *Open Source Solutions in Experimental Design* (January 2022, Society for Integrative and Comparative Biology [SICB]) focused on building a community of practice for the use of open source technology and software in biology (Box 1). Open source solutions not only are practical additions to the modern toolkit for experimental biologists, but also represent an increased emphasis on information sharing and collaboration in our field. While this was the first symposium of its kind in the USA, its interdisciplinary support at SICB was a signal of the growing popularity of open source technology worldwide. As a historic milestone, this symposium has resulted in some of the only methods papers focused on open source experimental design in *Integrative & Comparative Biology* or any other biology-focused journals (for journals focused on this

literature, see the *Journal of Open Hardware* and *HardwareX*). The symposium was also held during the first hybrid conference hosted by SICB, which leveraged the unique advantages of the open source community we hope to foster within SICB membership.

While there are countless technical and financial advantages to integrating open source solutions into every biologist’s experimental design (Landrain et al. 2013; Pearce 2015; Maia Chagas 2018), we put an emphasis on the “people” part of the equation in our symposium. Specifically highlighting innovative work by early career scientists from all backgrounds shows the core strength of the Open Science movement: access for all. We hoped to illuminate the breadth of possibility and creativity in open source solutions for biology and start the conversation among SICB members to further collaborate in this space.

Advance Access publication August 11, 2022

© The Author(s) 2022. Published by Oxford University Press on behalf of the Society for Integrative and Comparative Biology. All rights reserved. For permissions, please e-mail: journals.permissions@oup.com

Box 1. Community norms and key definitions highlighted in the *Open Source Solutions in Experimental Design 2022* symposium.

Open Source Community norms (modified from *The Open Source Initiative*: <https://opensource.org/osd-annotated>)

- Free redistribution
- Source code/plans available
- Modifiable by user
- Clear annotation of authorship
- No discrimination against peoples, groups, or uses
- License not limited to specific products, uses, or complementary technologies

Open Technology definitions for this symposium

Open source hardware: parts and electronic components for which design plans are freely available and integration does not require proprietary licensing

Open source software: developer code is available for all edit history and freely downloadable, for use with any technology

Open source user-end products: integration of open source hardware and software that offers a user-friendly experience with few developer skills

Recent advances in biological open hardware

The open hardware and software movements have had contrasting levels of popularity among experimental biologists, with the former restricted to a small but vibrant community and the latter adopted almost ubiquitously. Many experimental biologists use open source software daily, whether that is in statistical analyses or bioinformatics pipelines, but we want to highlight some of the lesser known open source software applications. In the symposium, we heard from one of the developers of FathomNet (www.fathomnet.org), which harnesses global community scientists to train artificial intelligence programs to identify deep sea creatures. [Curlis et al. \(2022\)](#), provided an automated image segmentation platform designed to manage non-standard body forms. Open source software is particularly powerful for teaching and student involvement in research ([Tanner R, Moore T. 2022](#)) because of its modular design and virtual accessibility, which can free researchers from depending on physical laboratory spaces. GitHub remains the premier forum for finding open source software and its community of developers.

Open hardware in biology has been slower to receive widespread adoption; however, the array of tech-

nological solutions is vast and inexpensive ([Oellermann et al. 2022](#)). Hardware solutions are designed and implemented more frequently by researchers in engineering, which draws a parallel to the challenges once faced by computer scientists interfacing with bioinformatics over the last few decades. There are three open source hardware areas in which we have seen significant innovations in the last few years: electronics, imaging, and 3D printing. In electronics, the rapid proliferation of microcontroller prototyping boards has provided a near-endless supply of platforms on which to base small process control or data collection/logging tasks. With over 200 Arduino-compatible boards alone, a dizzying array of features and form factors, and exceptionally low prices (such as the Seed Studios Seeduino Xiao, a thumbnail-size microcontroller with dual-core 133 MHz processors that sells for \$5.40), researchers now have a deep well of resources that is approachable even to novices. Development board-based cameras, like the \$35 64MP Arducam Pi Hawk-eye, which can readily be used with microcontrollers and single-board computers, have drastically improved access to high-quality imaging. Additionally, the dramatic price drop in high-quality 3D printing over the last decade, exemplified by FDM and resin printers available for under \$200, has made rapid, small-volume prototyping available to nearly any lab. The power of these recent innovations to advance biological research was highlighted in the contributions to this symposium, from octopus behavior field cameras to nocturnal bird tracking mechanisms, from plant biomechanics phenotyping to 3D insect modeling, and much more.

[Miller \(2022\)](#), presented a modern solution to bivalve physiological monitoring in the field and lab that takes advantage of custom printed circuit boards, a variety of inexpensive sensors, and the Arduino microcontroller (<https://www.arduino.cc>; Somerville, MA, USA). [Plum and Labonte \(2021\)](#), showcased a 3D scanner for producing arthropod models using open source hardware and software. [Heuschele et al. \(2022\)](#), provided a logging measurement device built on an Adafruit microcontroller, designed to capture real-time effects of wind on stem velocities. [Honeycutt and Bridge \(2022\)](#), presented an automated tracking telescope for nocturnal migration patterns called “LunAero.” [Humbert et al. \(2022\)](#), designed underwater field cameras with Raspberry Pi microcontrollers (<https://www.raspberrypi.com>; Cambridge, UK) that were deployed for multiple days on a single battery charge. The innovative experimental solutions presented by early career researchers in this symposium provided an impressive sample of the types of open source hardware and software solutions becoming available. But more importantly, their inclusion in this *Integrative & Comparative Bi-*

ology issue means that their replication is possible without seeking out more information in the open source community. We hope these resources being readily available here will allow researchers to feel at ease seeking out more knowledge equipped with the terminology familiarized within this symposium's papers.

Open Technology and access to experimental science

Accessibility can mean many different things. Accessibility in the physical sense can encompass design solutions for visual, auditory, or mobility limitations in the traditional notion of what experimental biology entails. Accessibility can also mean design solutions that are friendly to neurodiverse individuals in their administration and presentation. Experimental design can also be accessible in how it presents opportunities for individuals, the resources it demands, and the knowledge it requires to undertake. Open source experimental design is one step towards a more accessible future for experimental biology because of its flexibility, relatively low cost, primarily web-based distribution, and modular use.

Incorporating Universal Design for Learning into the classroom may be familiar to researchers engaged in the teaching aspect of higher education (Hitchcock et al. 2002), but rarely do its principles carry over into widespread experimental research design. A few studies have highlighted the utility of open source technology in making assistive devices more affordable in the classroom lab setting (Soong et al. 2018; Lee and Tucker-Kellogg 2020), and we argue that even research laboratories can take advantage of these same principles to make more opportunities for assistive devices in experimental biology research. Open source software is also fully customizable in appearance, which can allow developers to prioritize accessibility for users by choosing certain fonts, colors, and arrangements of information on the interface or tactile buttons on the physical product. Open source technology is also based exclusively in an online community, meaning it is easily reproducible in any geographic area and often hosted virtually. This means that the use of experimental design technology is accessible to researchers who do not physically reside in a specific lab, or cannot routinely visit their assigned lab space at a university or corporation. Digital analyses can be hosted in the cloud and inexpensive hardware components can be reproduced at a relatively large scale, allowing them to be shipped to more researchers. Taken together, this set of accessibility considerations make open source experimental design solutions an attractive consideration for researchers eval-

uating the relative impact of their science—not just on their field, but with the inclusion of their potential and current colleagues.

The last barrier that open source technology may build equity upon is in the financial realm. Unfortunately, most scientists do not have adequate funding to pursue the research they wish. The burden of underfunding falls disproportionately on people of marginalized groups due to systemic biases in research funding, evidenced by findings that Black and Asian PIs are awarded NIH R01 grants at significantly lower rates than their white counterparts (Ginther et al. 2011) and female PIs having lower funding rates on NIH R01 applications after their first grant award (Pohlhaus et al. 2011). This is likely one of the major reasons that there are persistent gaps in the representation of women and black, indigenous, and people of color (BIPOC) in many scientific fields (Bernard and Cooperdock 2018; Hamrick 2021). However grim the funding situation is in North America and Europe, research money is far more limited in emerging nations (Alemayehu et al. 2018). This is why organizations seeking to increase scientific research infrastructure in such places, such as TReND in Africa, have leaned heavily on open hardware to increase scientific capacity in underfunded regions (Baden et al. 2020). While by no means a substitute for addressing disparities in funding rates, Open Technology has a lower cost barrier to participation than traditional research infrastructure and allows broader participation in the scientific process.

One practical open source solution for experimental biology: cost and effort comparison

We provide an illustration of the accessible Open Technology principle by presenting an open source solution for \$83.96 that replaces a \$1461 “cheap” closed source unit, all assembled in <15 min. Water baths, used to maintain a precise and constant temperature for a variety of applications, are an important and ubiquitous piece of biological equipment, but they can be tens of thousands of dollars for the most precise instruments. The rice cooker water bath can be easily constructed by even electronics novices using an Arduino nano clone, an Adafruit MAX31865 RTD temperature sensor breakout board, a 16 × 2 character LCD screen, an AC power relay module, and a used rice cooker (Table 1).

The construction is, in short, accomplished by connecting the Arduino nano to the Adafruit MAX31865 on a breadboard, the 1602 LCD to the Arduino nano, and the AC relay to the Arduino nano (Fig. 1; complete assembly instructions are available at <https://youtu.be/M0RC5uQfqGg>). Next, the three-wire PT100 temper-

Table 1 Components used to construct the rice cooker water bath.

Part	Price
Arduino nano clone	\$7.60
1602 LCD screen	\$6.95
AC relay module	\$29.95
Adafruit MAX31865	\$14.95
PT100 temperature sensor	\$11.99
Second-hand rice cooker	\$6.99
Male–male jumper wires	\$1.95
Female–male jumper wires	\$1.95
Breadboard	\$1.99
Total	\$83.96

ature sensor is attached to the Adafruit MAX31865 by connecting the two red wires to the RTD+ and the blue wire to the RTD– screw terminals. The Arduino nano could then be programmed with the provided code using the Arduino IDE (<https://doi.org/10.5281/zenodo.6438456>), the temperature sensor placed into the rice cooker, and the rice cooker plugged into one of the “normally on” receptacles on the AC relay. A water bath constructed this way, and with the simple code provided, is capable of better than $\pm 0.5^{\circ}\text{C}$ temperature control from ambient to 100°C . No-cost improvements, such as implementing a PID controller in the Arduino con-

trol code and substituting a PT100 for a PT1000, can yield greater than $\pm 0.1^{\circ}\text{C}$ temperature control. The cost of this assembly was $< \$85$ (Table 1), while equivalent functionality often costs at least 10x that amount to purchase from traditional scientific equipment supply companies (currently \$1461 for a Grant Instrument 2 L SUB AQUA PRO water bath on www.VWR.com). With the appropriate materials on hand, the entire construction can be accomplished in < 15 min.

Call for specific actions toward the adoption of open hardware in biology

The Open Science movement operates within community norms that champion transparency, continuous development, and collaboration (Box 1). These values are congruent with the priorities of reducing barriers to participation in science. A future of decreased funding barriers to participation in experimental biology is important for realizing the goals of a more equitable research community. Additionally, open source technology allows for innovation in experimental design that champions accessibility, not only in the financial respect but also in accommodating design aspects.

In this symposium, we set out to establish a community of practice for open source technology among SICB members. While the hybrid event made networking in this space difficult, we still see the inclusion of open source technology methods in papers in the *In-*

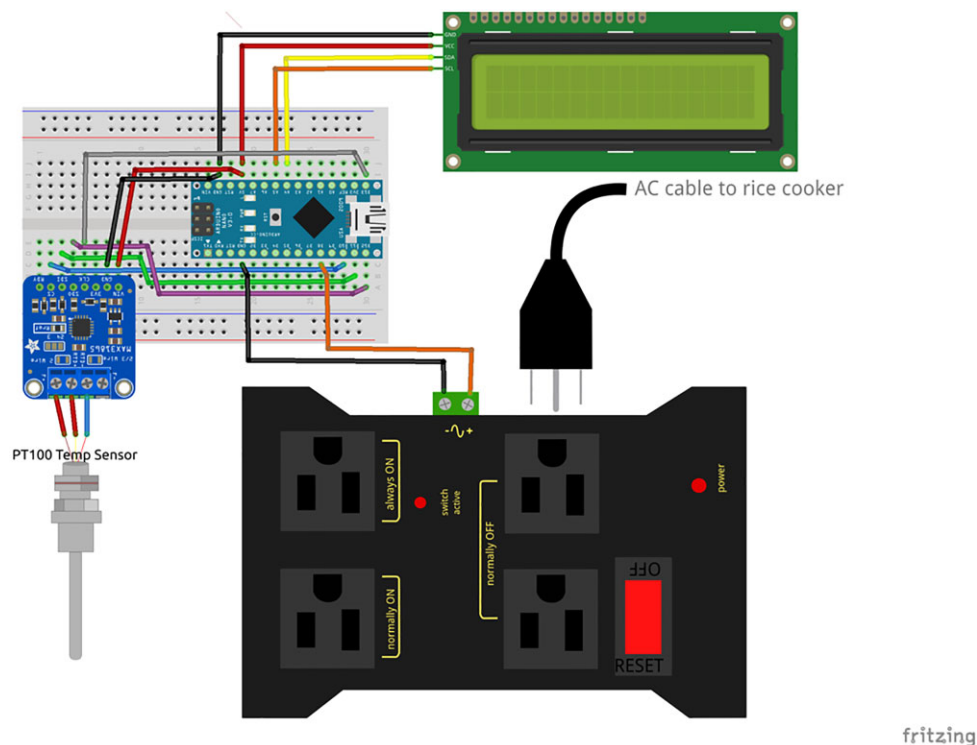

Fig. 1 Fritzing diagram of rice cooker.

egrative & Comparative Biology journal as a successful first step toward normalizing these methods in experimental biology. We urge researchers who use these types of experimental solutions to detail their designs within the method sections of their research articles and include part lists (and manufacturers, if applicable) in supplementary materials. We suggest that researchers unfamiliar with the Open Science community seek out basic tutorials and tinker with starter kits from well-documented brands such as Raspberry Pi and Arduino. A comprehensive list of existing communities of practice for open hardware design is included in [Oellermann et al. \(2022\)](#). Lastly, we encourage researchers to collaborate with colleagues on methodology and experimental design to further defray the cost of manufacturing and development, and ultimately foster a greater sense of community around experimental design innovation.

Acknowledgments

We thank the speakers and attendees within this symposium for their inspiration and participation, in particular Michael Oellermann for his co-facilitation of the European analog of this symposium with RLT at the Society for Experimental Biology in July 2021.

Competing Interest

The authors declare no competing interests.

Funding

This work was supported by the Society for Integrative and Comparative Biology.

Data Availability

No data were used in the preparation of this manuscript.

References

- Alemayehu C, Mitchell G, Nikles J. 2018. Barriers for conducting clinical trials in developing countries—a systematic review. *Int J Equity Health* 17:1–11.
- Baden T, Maina MB, Chagas AM, Mohammed YG, Auer TO, Silbering A, von Tobel L, Pertin M, Hartig R, Aleksic J et al. 2020. TReND in Africa: toward a truly global (neuro)science community. *Neuron* 107:412–16.
- Bernard RE, Cooperdock EH. 2018. No progress on diversity in 40 years. *Nat Geosci* 11:292–95.
- Curlis J, Renny T, Rabosky A, Moore T. 2022. Batch-Mask: automated image segmentation for organisms with limbless, elongate, or otherwise non-standard body forms. *Integr Comp Biol* (doi: 10.1093/icb/icac036).
- Ginther DK, Schaffer WT, Schnell J, Masimore B, Liu F, Haak LL, Kington R. 2011. Race, ethnicity, and NIH research awards. *Science* 333:1015–9.
- Hamrick K. 2021. Women, minorities, and persons with disabilities in science and engineering (Special Report NSF 21-321). National Science Foundation: Alexandria, VA, USA.
- Heuschele D, Furuta D, Smith K, Marchetto P. 2022. Capturing high resolution plant movement in the field. *Integr Comp Biol* (doi: 10.1093/icb/icac075).
- Hitchcock C, Meyer A, Rose D, Jackson R. 2002. Providing new access to the general curriculum: universal design for learning. *Teach Except Child* 35:8–17.
- Honeycutt W, Bridge E. 2022. Use of the LunAero open-source hardware platform to enhance accuracy and precision of traditional nocturnal migration bird counts. *Integr Comp Biol* (doi: 10.1093/icb/icac053).
- Humbert J, Williams K, Onthank K. 2022. Den associated behavior of *Octopus rubescens* revealed by a motion-activate camera trap system. *Integr Comp Biol* (doi: 10.1093/icb/icac124).
- Landrain T, Meyer M, Perez AM, Sussan R. 2013. Do-it-yourself biology: challenges and promises for an open science and technology movement. *Syst Synth Biol* 7:115–26.
- Lee NY, Tucker-Kellogg G. 2020. An accessible, open-source mobile application for macromolecular visualization using augmented reality. *Biochem Mol Biol Educ* 48:297–303.
- Maia Chagas A. 2018. Haves and have nots must find a better way: the case for open scientific hardware. *PLoS Biol* 16:e3000014.
- Miller L. 2022. Monitoring bivalves in the laboratory and field using open source tools. *Integr Comp Biol* (doi: 10.1093/icb/icac046).
- Oellermann M, Jolles J, Ortiz D, Rui S, Wenzel T, Wilson H, Tanner R. 2022. Harnessing the benefits of open electronics in science. *Integr Comp Biol* doi: 10.1093/icb/icac043).
- Pearce JM. 2015. Quantifying the value of open source hardware development. *Mod Econ* 06:1–11.
- Plum F, Labonte D. 2021. scAnt—an open-source platform for the creation of 3D models of arthropods (and other small objects). *PeerJ* 9:e11155.
- Pohlhaus JR, Jiang H, Wagner RM, Schaffer WT, Pinn VW. 2011. Sex differences in application, success, and funding rates for NIH extramural programs. *Acad Med* 86:759.
- Soong R, Agmata K, Doyle T, Jenne A, Adamo T, Simpson A. 2018. Combining the maker movement with accessibility needs in an undergraduate laboratory: a cost-effective text-to-speech Multipurpose, Universal Chemistry Sensor Hub (MUCSH) for students with disabilities. *J Chem Educ* 95:2268–72.
- Tanner R, Moore T. 2022. Virtual expeditions broaden student participation in natural history research. *Integr Comp Biol* (doi: 10.1093/icb/icac065).
- Curlis JD, Renny T, Rabosky ARD, Moore TY. 2022. Batch-Mask: Automated Image Segmentation for Organisms with Limbless or Non-Standard Body Forms. *Integrative and Comparative Biology* (doi: 10.1093/icb/ica036).